

VOLVO PENTA RUBBER STUFFING BOX



The rubber stuffing box is a well proven product for sealing and lubrication. It can be used on any marine vessel that comes with shaft installation.

Long life sealing

The rubber stuffing box provides versatility and long time sealing with very limited maintenance.

Volvo Penta design

The seal is a Volvo Penta design with all the requirements for safety, functionality and ease of assembly that have become a trademark for Volvo Penta products. The functionality with recirculating water that lubricates the seal is as secure and fault free as the design is simple.

Maintenance

The rubber stuffing box offers a low maintenance solution and yet offers a long life span when handled properly. Apply grease every 200 running hours or once a year and ventilate the seal after launching the boat for many years faultless function.

Easy to install

The seal is very easy to install due to its compact and simple design. Install it under the waterline and ensure that sea water is circulating through the inside of the seal to ensure full lubrication that will secure the function. It will provide a long lasting and low cost solution that already is so appealing to many boaters in the world. Some installations may require extra water supply to offer proper function.

Benefits

- Easy and quick installation.
- Compact size.
- Minimal maintenance.
- Effective functionality
- Offers many years faultfree function
- Great for repowering

**VOLVO
PENTA**

PRODUCT INFORMATION

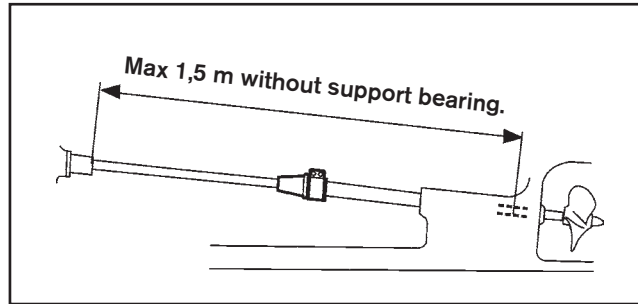

It's crucial that the shaft is within tolerance and straight or the installation may cause damage to the seal and leakage into the boat.

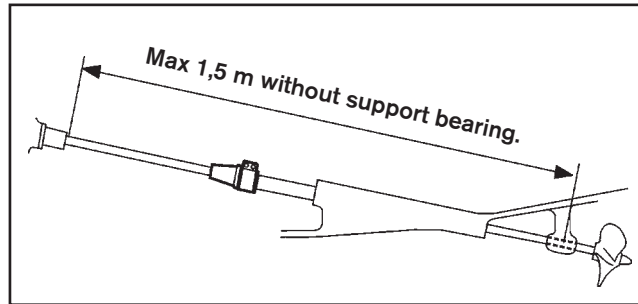

Always install the water lubricated seal under the waterline to ensure proper function.

In some applications a separate water supply may be required to ensure proper function.

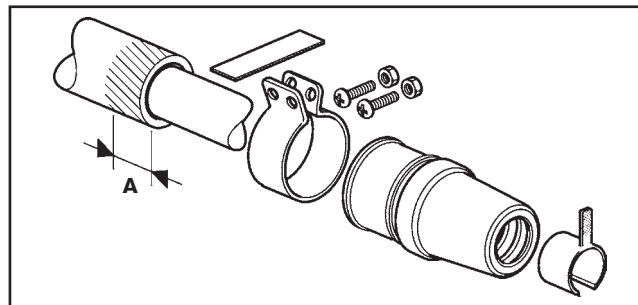

Always make sure that there is a minimum of 36 mm's (A) length at the end of the sleeve to ensure a proper assembly.

Components

Shaft diameter		Sleeve diameter		Part no.
25 mm	(+0 / -0.1)	42 mm	(+0.5/-0.3)	828254
30 mm	(+0 / -0.1)	48 mm	(+0.5/-0.3)	828422
35 mm	(+0 / -0.15)	54 mm	(+0.5/-0.3)	828526
40 mm	(+0 / -0.15)	60 mm	(+0.5/-0.3)	828527
45 mm	(+0/-0.2)	64 mm	(+0.5/-0.3)	3819722
50 mm	(+0/-0.2)	70 mm	(+0.5/-0.3)	3819723
1 "	(+0/-0.1)	1 3/4"	(+0.5/-0.3)	3819724
1 1/4"	(+0/-0.1)	2"	(+0.5/-0.3)	3819725
1 1/2 "	(+0/-0.15)	2 1/4"	(+0.5/-0.3)	3819726
1 3/4 "	(+0/-0.2)	2 1/2"	(+0.5/-0.3)	3819727
2 "	(+0/-0.2)	2 3/4"	(+0.5/-0.3)	3819728

Note! The rubber stuffing box is not recommended for installations where flexible couplings are being used.

VOLVO PENTA

AB Volvo Penta

SE-405 08 Göteborg, Sweden